

3138-TS Printer Applicator Specifications

Dimensions:

Height: 23.88" (606.62 mm)
 Length: 30.52" (775.12 mm)
 Width: 26.97" (684.99 mm)

Weight:

165 lbs. (75 kg)

Standard Label Dimensions:

Label Width: Up to 7.2" (183 mm)
 Label Length: Up to 7" (178 mm)
(Printer dependent)

Dispense Speed:

Up to 16" (305 mm) per second
 depending on printer and label size

Label Placement Accuracy:

+/- 1/32" (.8 mm)

Electrical:

115 Volts AC 60 Hz 5 Amps.
 220 Volts AC 50 Hz 2.5 Amps.

Air:

4 cfm at 90 psi for most applications

Options:

Most O.E.M. print engines
 17" (432 mm) powered unwind
 Label on pad detection
 Air-Blow conversion
 90° swing tamp configuration
 Dual Action Tamp (DAT) configuration
Consult factory for additional options.

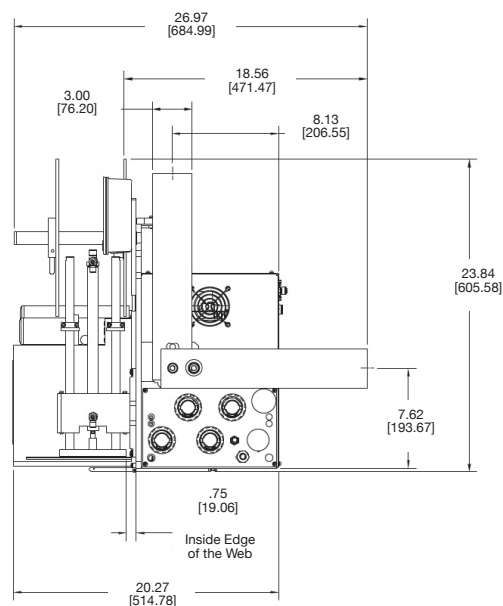
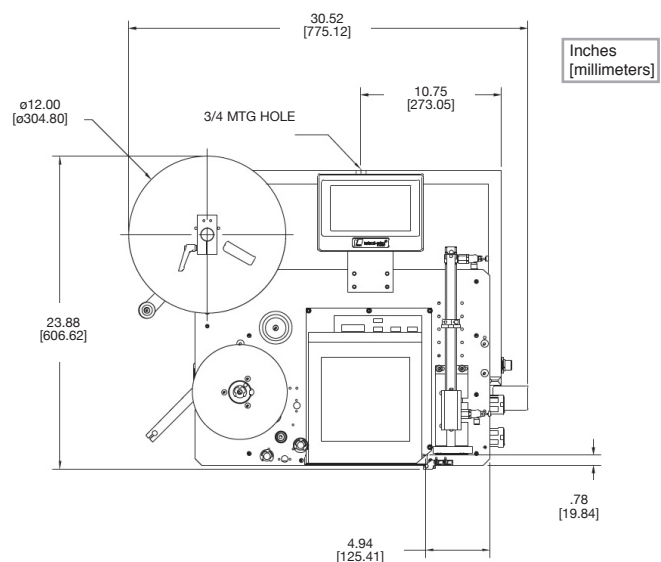

Inches
[millimeters]



Model 3138-TS

Have a Label-Aire Authorized Distributor contact you. Visit www.label-aire.com.



Headquarters

550 Burning Tree Road
 Fullerton, CA 92833 USA

o 714.449.5155
 f 714.526.0300
 e info@label-aire.com
 w www.label-aire.com

Europe

Via Bacchini 3/b
 40026 Imola (BO), Italy

o +39.0542.1903925
 f +39.0542.1903895
 e info@label-aire.com
 w www.label-aire.com

Asia

27 Yucheng Road,
 Taiping, Taichung
 41155 Taiwan

o +886.987.968.513
 f +886.4.2395.80 07
 e info@label-aire.com
 w www.label-aire.com



3138-TS

Printer Applicator

- Available at a lower cost
- New split cover for easier access
- Easier tamp assembly field kit installation
- New pneumatic panel for easy component replacement
- Redesigned electronics tray
- 1" to 10" (25.4 mm to 254 mm) adjustable tamp assembly
- Ambidextrous parts
- RFID configurable

Model 3138-TS

The Label-Aire® Model 3138-TS Printer Applicator works hard for you... so you don't have to.

The Model 3138-TS Printer Applicator delivers on its promise of accuracy, reliability, and ease of use. That translates into lower operating costs and increased productivity for your business.

The 3138-TS is Label-Aire's most advanced printer applicator which features New Generation technology making it the ideal choice for the most demanding applications. Advanced features include automatic setup with multiple programmable label pages for easy change-overs to labels of different sizes, rate compensation for improved label placement accuracy, and advanced user-configurable I/O connectivity. The 3138-TS's newest features consist of a split cover for easier access, easier tamp assembly field kit installation, a redesigned electronics tray for top access, a new pneumatic panel for easy component replacement, 1" to 10" (25.4 mm to 254 mm) adjustable tamp assembly with stainless steel rods and locking collars, ambidextrous parts—unit can be reassembled in opposite hand configuration, and the 3138-TS is RFID configurable. All these handy features greatly simplify setup and changeovers. The 3138-TS is just as tough as it is advanced. Its rugged stainless steel and anodized aluminum construction is corrosion resistant providing long-lasting durability and maintenance-free operation in the most hostile environments. Options include a 17" (432 mm) powered unwind, label on pad detection, Air-Blow labeling coTersion, 90° swing tamp configuration, and Dual Action Tamp (DAT) configuration. Like all Label-Aire printer applicators, the 3138-TS is compatible with most O.E.M. printers.

Put this most advanced printer applicator to work for you all day, every day. The Model 3138-TS Printer Applicator is built to meticulous quality standards and designed to withstand the most intense operation.

3138-TS Advanced Features	
Automatic setup	Includes multiple programmable label pages for easy change-overs to different label sizes.
Split cover	Allows easier access to electronics.
Pneumatic panel	For easy component replacement.
Ambidextrous parts	Allows easy reassembly in opposite hand configuration.
1" to 10" (25.4 mm to 254 mm) adjustable tamp assembly	Consists of steel rods, locking collars, and heavy duty air cylinder for 24/7 label application.
HMI color touch screen	Touch screen allows easy set-up and adjustability.
Flash memory	Allows easy download of system software updates.
Rate compensation	For improved label placement accuracy.
Advanced I/O	User-configurable for system output.
Stepper rewind	Comes standard for waste take up.
17" (432 mm) powered unwind	Optional configuration is geared for high-speed, heavy duty operation.

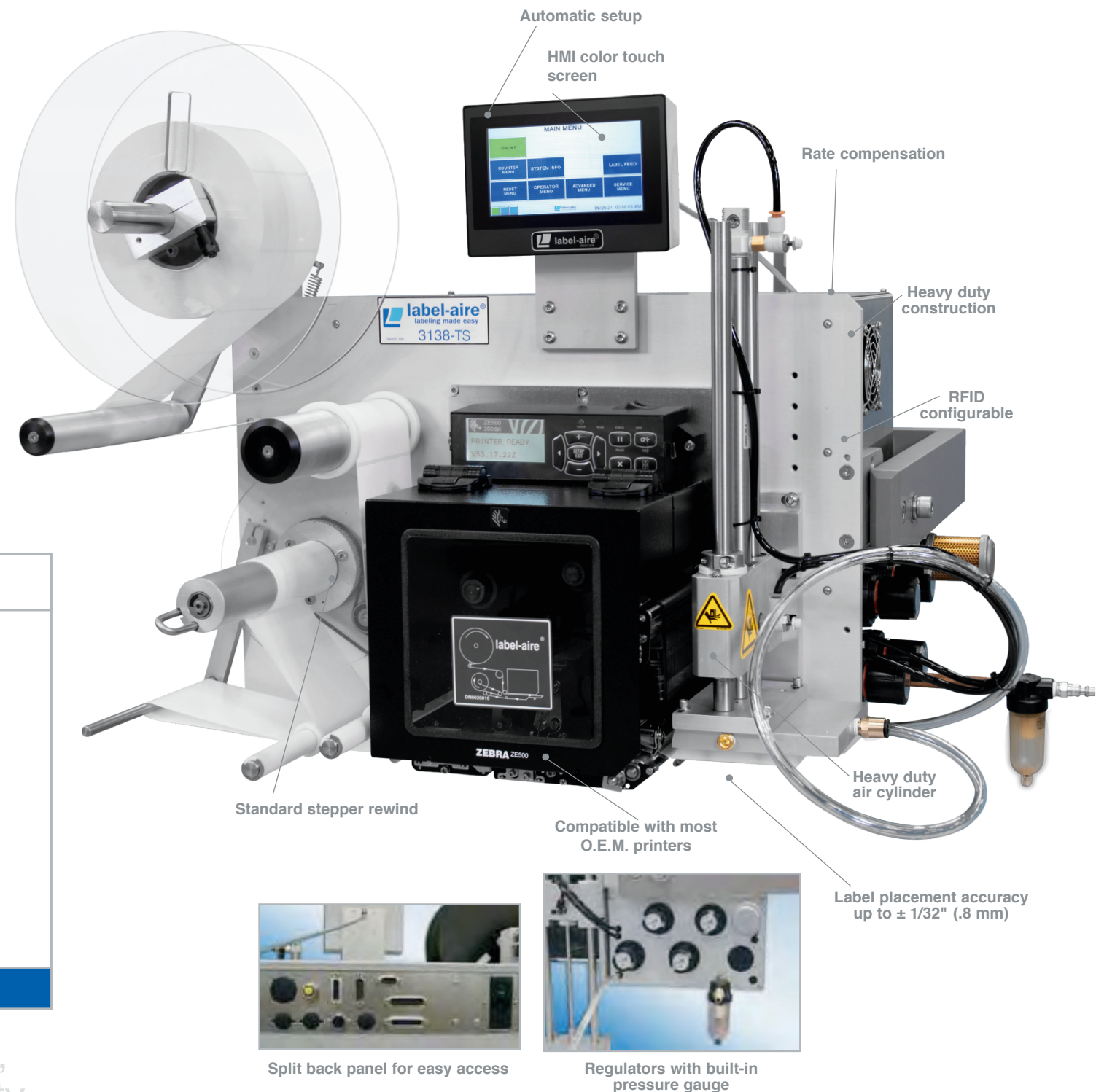

beverage, cd / dvd, coupon / promotional, dairy, direct mail, durable goods, food, health & beauty, nutraceutical, pharmaceutical, tamper-evident labeling