

# Model 3125-TS



## 3125-TS Wipe-On

Primary Applicator

The **Label-Aire® Model 3125-TS** makes labeling easier and faster...making you more profitable.

The Model 3125-TS Wipe-On labeler delivers on its promise of speed, accuracy, and ease of use. And that translates into lower operating costs and increased productivity for your business.

Speeds up to 2,500 inches (63.5 m) of web per minute make the Model 3125-TS an ideal choice for demanding applications requiring high speed and precision. Advanced features include Automatic Speed Following (ASF) which allows product surface profiling, ensuring wrinkle-free labeling on even the most difficult product shapes and label materials (optional encoder required). Zero Downtime Labeling allows your production to continue without costly interruptions. Product/label queuing and missing label compensation virtually eliminate unlabeled products or missing lot and expiration codes.

Put this high-speed wipe-on pressure-sensitive technology to work for you all day, every day. The Model 3125-TS Wipe-On labeler is built to meticulous quality standards and designed to withstand the most demanding operation.

Have a Label-Aire Authorized Distributor contact you. Visit [www.label-aire.com](http://www.label-aire.com).



# 3125-TS Wipe-On Specifications

## Dimensions:

Height: 39.20" (995.76 mm)  
 Length: 43.57" (1,106.66 mm)  
 Width: 26.61" (675.93 mm)

## Weight:

160 lbs. (73.6 kg)

## Standard Label Dimensions:

Max. Web Width: 7.13" (181 mm)  
 Min. Web Width: 1" (25 mm)  
 Min. Label Length: .5" (13 mm)

## Label Packaging:

16" (406 mm) O.D. rolls std. on  
 3" (76 mm) I.D. cores with optional 6"  
 (152 mm) core adapters

## Dispense Speed:

2,500" (63.5 m) of web per minute

## Label Dispense Accuracy:

Up to +/- 1/64" (.4 mm)

## Electrical:

115 Volts AC 60 Hz 3 Amps.  
 220 Volts AC 50 Hz optional

## Options:

6" (152 mm) label core adapter  
 Encoder kit for Automatic  
 Speed Following  
 Strobe signals for "low label" and  
 "out of labels"  
 Clear label sensor upgrade  
 Hot stamp imprinter  
 Display tilt mounting brackets  
**Consult factory for additional options.**

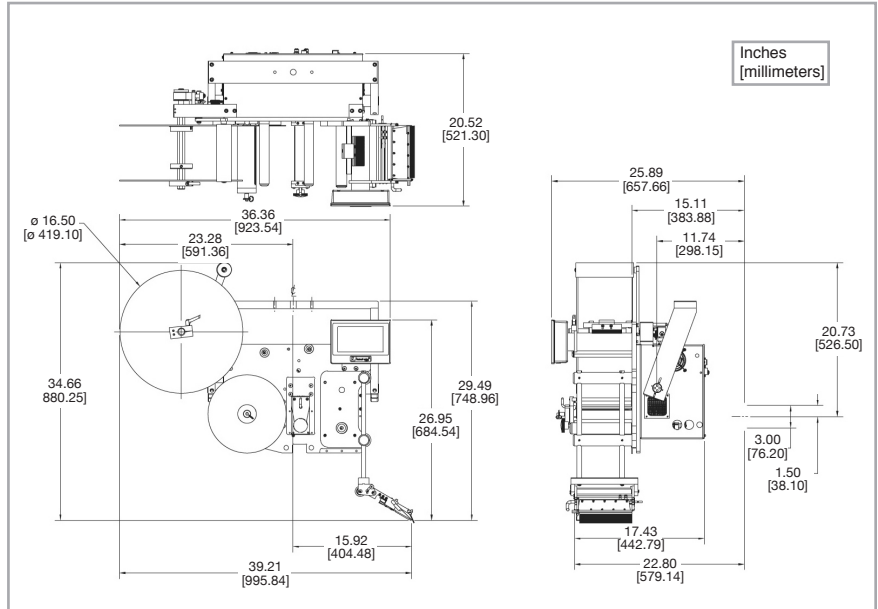

Stated dimensions are approximations. Please consult factory if dimensions are required for line integration.

## 3125-TS Wipe-On Advanced Features

<b>Automatic setup</b>	Includes multiple programmable label pages for easy changeovers to different label sizes.
<b>Stepper motor drive</b>	For precise starting/stopping, increased reliability, wider range speed variability, and lower maintenance.
<b>HMI color touch screen</b>	Touch screen allows easy set-up and adjustability.
<b>Automatic Speed Following (ASF)</b>	Labels are accurately applied even through extreme changes in product line speed.
<b>Quick-action collapsible rewind</b>	Allows easy removal of scrap liner.



### Headquarters

550 Burning Tree Road  
 Fullerton, CA 92833 USA

o 714.449.5155  
 f 714.526.0300  
 e info@label-aire.com  
 w www.label-aire.com

### Europe

Via Bacchini 3/b  
 40026 Imola (BO), Italy

o +39.0542.1903925  
 f +39.0542.1903895  
 e info@label-aire.com  
 w www.label-aire.com

### Asia

27 Yucheng Road,  
 Taiping, Taichung  
 41155 Taiwan

o +886.987.968.513  
 f +886.4.2395.80 07  
 e info@label-aire.com  
 w www.label-aire.com

Distributed by:

